

Order No.: 65/0-N

For filters

For filter pressure regulators

For combination units

For mounting to compressed air tanks, compressed air lines, etc.

Fully automatic, float operated drain valve for draining liquid impurities from the compressed air separated by filters, etc.

Installation

The automatic drain valve can be screwed into any filter, filter pressure regulator or combination unit (minimum size: "small" (R 1/4)) instead of the manually operated drain valve. Port size: G 1/8. Designed for vertical mounting $\pm 15^\circ$.

The discharge opening has an R 1/4 thread for connecting a discharge pipe.

To prevent backing-up, this pipe should have a minimum inside diameter of 6 mm.

Technical data:

Min. operating pressure: 4 bar

Max. operating pressure: 12 bar

Temperature: -10°C to $+90^\circ\text{C}$

Principle

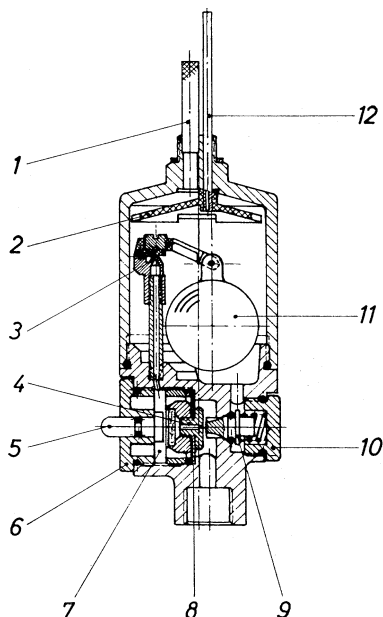

The liquid impurities that are separated in the filter or a compressed air tank enter the float chamber of the drain valve via the bore in the nozzle. Coarse impurities that could impair the ability of the drain valve to operate are retained by the strainer (1). The pressure between the filter bowl and the float chamber is compensated by the riser (12). As the liquid level increases, the float (11) begins to rise and makes the nozzle bore (3) accessible by operating a lever. Liquid flows through this bore into the diaphragm chamber (7), lifting the cone seal (9) from the seat (9) as the diaphragm bulges outwards. The liquid is then forced out through the discharge opening by the air pressure. When the float chamber has been completely drained, the float sinks back down to the bottom and the nozzle bore is closed. The compressed air in the diaphragm chamber escapes through the nozzle hole (4) in the diaphragm screw, causing the drain valve to close again. Compressed air is blown through briefly as a result of this delayed closure, thereby cleaning the valve seat and ducts. A drainage cycle can also be activated by pressing the actuator pin (5) (pliers must be used to do this at high pressures).

Maintenance

The drain valve requires virtually no maintenance. In case of severe fouling or media with a tendency to stick, the diaphragm chamber and the cone seal can be cleaned after removing the knurled screws (6) and (10). The float chamber can be accessed for cleaning after unscrewing the valve manifold. Commercially available fluids such as naphtha, tri, etc. are suitable for this purpose. Seals (O-rings) should only be exposed to the action of cleaning agents for a short time and must subsequently be greased.