

REED sensor

ZRL1 series

Art. No. 129638

Type No. RS.ZRL1.K5



Exemplary illustration

Technical data

For cylinders	ZRL1C, ZRL1F, ZRL1S
Description	REED sensor, 5 m cable with open strands, 5-130V AC/DC, 6W, NO, LED

Commercial data

Customs tariff number	85363010
Country of origin	IT
eCl@ss 5.1.4	27299201
eCl@ss 9.0	27299201
UNSPSC_Code_v190501	39122241
UNSPSC_CodeDesc_v190501	Reed switch

Material informations

REACH SVHC1 substance name	no
CAS no. SVHC 1	no CAS No.
RoHS materials notice	RoHS compliant
REACH Info	no SVHC substance included

Sensors for ZRL1C, ZRL1F, ZRL1S

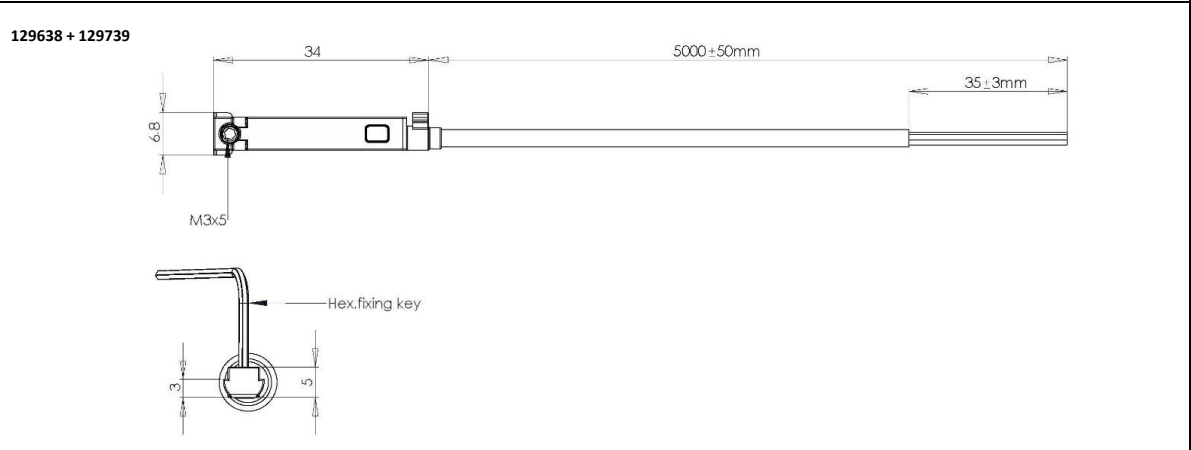
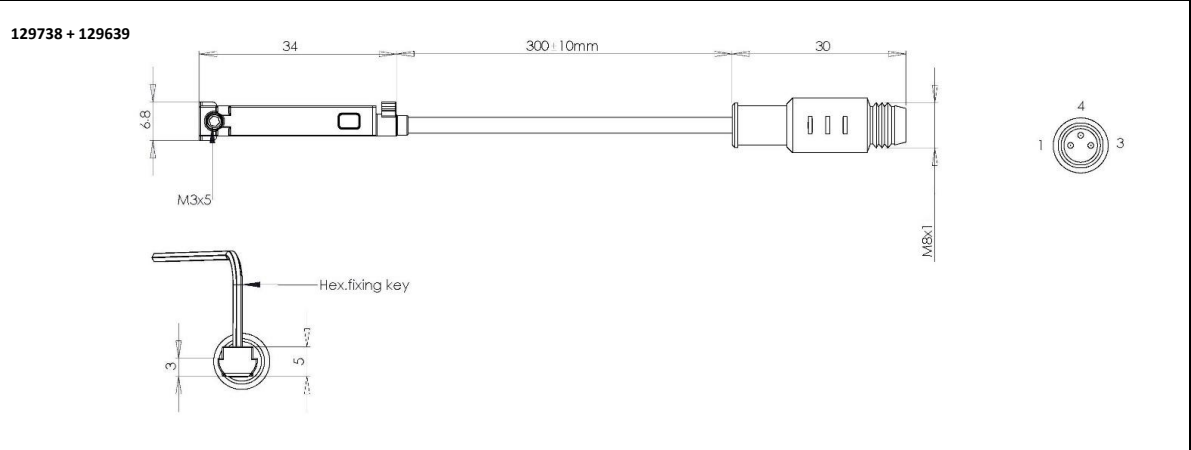

REED				HALL			
Art. No.	Type No.	Art. No.	Type No.	Art. No.	Type No.	Art. No.	Type No.
129638	RS.ZRL1.K5	129738	RS.ZRL1.M8	129739	HS.ZRL1.PNP.K5	129639	HS.ZRL1.PNP.M8

Switching function	NO						
Rated voltage	5 ... 130 V AC/DC		5 ... 50 V AC/DC		10 ... 30 V DC		
Max. current	200 mA						
Max. power	6 W			4 W			
Max. voltage drop	3 V			0.7 V			
LED color	yellow						
Number of contacts	2 x 0.14 mm ²			3 x 0.14 mm ²			
Cable	PUR, 5 m, Ø 2.7 mm		PUR, 300 mm, Ø 2.7 mm		PUR, 5 m, Ø 2.7 mm		PUR, 300 mm, Ø 2.7 mm
Temperature range (static installation)	-25 °C ... +70 °C						
Housing material	PA6						
Mounting	Headless screw M3x5						
Max. torque headless screw	0.15 Nm						
Protection class (when correctly assembled)	IP 67						
Switching time	1 ms			0,1 ms			
Electrical life	10 ⁷ (24 V DC, 10 mA)			10 ¹¹ (24 V DC, 10 mA)			
Wirin diagram	